

OUTDOOR BURNING

Appliances that burn flammable gases such as propane and LNG are not included in this by-law.

Outdoor wood burning appliances may be used throughout the Town, provided that the requirements outlined in By-law 500-11 have been met.

An appliance may either be commercially manufactured (no permit required) or homemade (requires a permit).

What you can burn in your appliance:

You can only burn dry, seasoned firewood in your appliance.

What you cannot burn in your appliance:

Do not burn pressure-treated or painted wood, leaves, grass, other vegetation, any plastic material, any food material or any material of any kind which produces an unreasonable amount of smoke or other respiratory irritants.

Be considerate of your neighbours:

Please use good judgement when using your wood burning appliance. Discuss it with your neighbours. Be considerate of people that suffer from allergies and respiratory problems.

When using an outdoor wood burning appliance, residents must ensure that:

- A functioning garden hose or portable fire extinguisher is near and readily available.
- Fires must be supervised at all times by a responsible adult.

INSIDE TOWN LIMITS

If you live within the Town of Riverview By-law 500-11 applies to you.

OUTSIDE TOWN LIMITS

Contact the Department of Natural Resources and Environment:
1-866-458-8080.

FIRE BANS

Wood burning appliances **cannot** be used in Riverview when the New Brunswick Department of Natural Resources and Environment have placed a ban on open burning in the area.

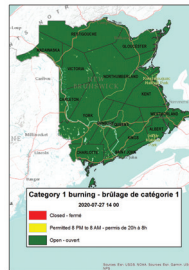

Online

www2.gnb.ca/content/gnb/en/news/public_alerts/forest_fire_watch.html

Call 1-866-458-8080

Riverview Fire and Rescue

650 Pinewood Road, Riverview
(506) 387-2026
fire@townofriverview.ca



townofriverview.ca

Guidelines for OUTDOOR BURNING



By-law 500-11

APPLIANCE LOCATION

- 1 The appliance shall not be placed within 3 m (10 ft.) from buildings, property lines, or anything combustible.
- 2 It must be placed on a non-combustible surface which extends 60 cm (2 ft.) outside of the appliance.
- 3 Only one appliance shall be used on a property at one time.

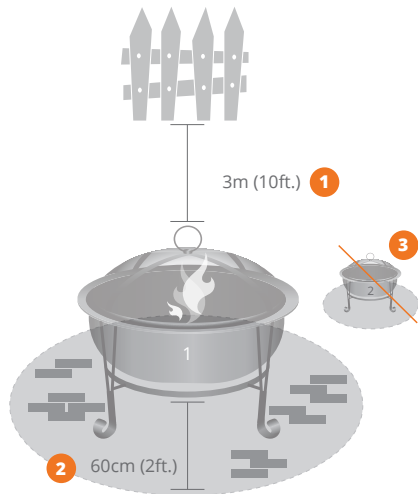

COMMERCIALLY MANUFACTURED APPLIANCE

Definition: A manufactured non-combustible enclosed container designed to hold a small fire for decorative purposes and the size of which is not larger than 1 m (3 ft.) in any direction, and may include, but not limited to, chimneys.

- A It must have a spark screen present when in use.
- B Providing the manufacturers' instructions for the safe installation and operation have been followed, no permit is required.

HOMEMADE WOOD BURNING DEVICE

A homemade wood burning device must be inspected and approved by a Fire Prevention Officer (a permit will be issued) prior to use.

The device must meet the following:

- A Must be less than 0.6 m (2 ft.) high.
- B Must be less than 1 m (3 ft.) wide.
- C Must have fully-enclosed sides made from non-combustible materials such as bricks, concrete or heavy gauge metal.
- D Must have a mesh screen on top to stop sparks (spark arrestor) with openings no larger than 1 cm (1/4 in.).
- E The location will be checked to ensure it is compliant with the by-law.

GENERAL INQUIRIES

For general inquiries or to arrange for an inspection, please call Riverview Fire and Rescue at 506-387-2026 or email: fire@townofriverview.ca